

**HARRISON COLLEGE**  
**END OF YEAR EXAMINATION 2019**  
**THIRD YEAR MATHEMATICS**  
**DURATION: 1 Hour and Fifty Minutes**

**GENERAL INSTRUCTIONS TO CANDIDATES**

- 1) **ALL QUESTIONS ARE TO BE ANSWERED IN THE SPACES PROVIDED ON THIS QUESTION PAPER. THERE ARE TWO EXTRA PAGES AT THE END OF THIS PAPER FOR ADDITIONAL OR ROUGH WORKING.**
  
- 2) This Examination Paper consists of **ELEVEN** printed pages and **TWO** blank pages.
  
- 3) All **TWENTY-TWO** questions are to be attempted.
  
- 4) Number your responses carefully and identically (including any associated parts) as they appear on the question paper.
  
- 5) Calculators are **ALLOWED**.
  
- 6) If a numerical answer cannot be given **exactly**, and the accuracy required is not specified in the question, then in the case of an angle it must be given correct to **one (1)** decimal place, in other cases it must be given correct to **three (3)** **significant figures**.
  
- 7) The maximum mark for this Examination is **90**.
  
- 8) Write your **NAME** and **FORM** below.

**NAME OF STUDENT:** \_\_\_\_\_

**FORM:** \_\_\_\_\_

**DO NOT TURN THIS PAGE UNTIL YOU ARE TOLD TO DO SO**

## LIST OF FORMULAE

Volume of Prism  $V = Ah$  where  $A$  is the area of a cross-section and  $h$  is the perpendicular length.

Volume of Cylinder  $V = \pi r^2 h$  where  $r$  is the radius of the base and  $h$  is the perpendicular height.

Volume of a right pyramid  $V = \frac{1}{3} Ah$  where  $A$  is the area of the base and  $h$  is the perpendicular height.

Circumference  $C = 2\pi r$  where  $r$  is the radius of the circle.

Arc length  $S = \frac{\theta}{360} \times 2\pi r$  where  $\theta$  is the angle subtended by the arc, measured in degrees.

Area of a circle  $A = \pi r^2$  where  $r$  is the radius of the circle.

Area of a sector  $A = \frac{\theta}{360} \times \pi r^2$  where  $\theta$  is the angle of the sector, measured in degrees.

Area of Trapezium  $A = \frac{1}{2}(a+b)h$  where  $a$  and  $b$  are the lengths of the parallel sides and  $h$  is the perpendicular distance between the parallel sides.

Trigonometric ratios

$$\sin \theta = \frac{\textit{opposite side}}{\textit{hypotenuse}}$$

$$\cos \theta = \frac{\textit{adjacent side}}{\textit{hypotenuse}}$$

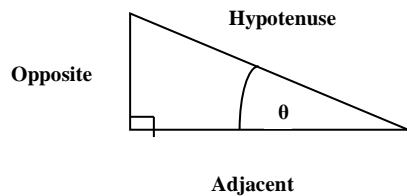
$$\tan \theta = \frac{\textit{opposite side}}{\textit{adjacent side}}$$

Area of a triangle Area of  $\triangle ABC = \frac{1}{2} bh$  where  $b$  is the length of the base and  $h$  is the perpendicular height.

Area of  $\triangle ABC = \sqrt{s(s-a)(s-b)(s-c)}$

where  $s = \frac{a+b+c}{2}$

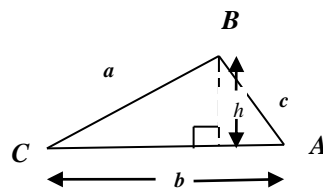

## SECTION I

**CIRCLE** the **LETTER** that matches your response for Questions 1) to 10).

1) If  $x * y$  is defined to be  $x \div 2y$ , then  $-3 * a$

- (A)  $-3 \div 2a$                       (B)  $2a \div (-3)$                       (C)  $3 \div 2a$                       (D)  $-3 \div a$

2)

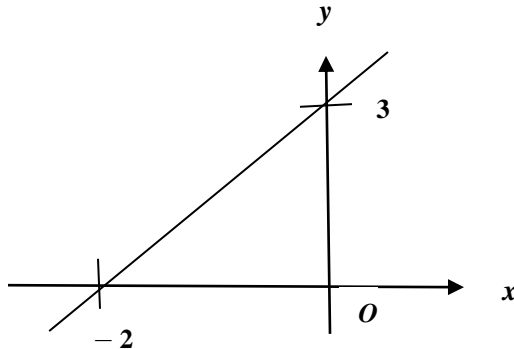

The diagram above illustrates the graph of

- (A)  $y = 3x - 2$                       (B)  $y = -2x + 3$                       (C)  $y = \frac{3}{2}x - 3$                       (D)  $y = \frac{3}{2}x + 3$

3) The gradient of the line parallel to  $3x - 2y = 1$  is

- (A)  $\frac{2}{3}$                                       (B)  $\frac{3}{2}$                                       (C)  $-\frac{3}{2}$                                       (D)  $\frac{1}{2}$

4) If  $\frac{2}{a+b} = \frac{1}{3}$ , then the value of  $\frac{a+b}{4}$  is

- (A)  $\frac{1}{12}$                                       (B)  $\frac{4}{3}$                                       (C)  $\frac{3}{2}$                                       (D) 12

5) A number,  $2p$ , is squared, then increase by 4. Algebraically, this may be represented as

- (A)  $2p^2 + 4$                               (B)  $(2p + 4)^2$                               (C)  $4p + 4$                               (D)  $4(p^2 + 1)$

6) If  $\frac{2}{p} + \frac{1}{q} = r$ , then  $p$  equals

- (A)  $r - \frac{1}{q}$                                       (B)  $\frac{2q}{qr - 1}$                                       (C)  $\frac{2}{qr}$                                       (D)  $\frac{qr}{2}$

Questions 7), 8) and 9) refer to the numbers below which represent the weights, to the nearest kilogram, of seven picture frames.

12, 20, 15, 42, 12, 12, 27

7) The modal weight of the picture frames, in kilograms, is

- (A) 42                                      (B) 12                                      (C) 27                                      (D) 15

8) The median weight of the picture frames, in kilograms, is

- (A) 20                                      (B) 27                                      (C) 15                                      (D) 42

9) The range of the data is

(A) 8

(B) 15

(C) 27

(D) 31

10)

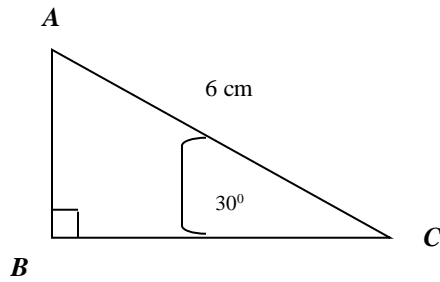

The triangle  $ABC$  above is right-angled at  $B$ . Angle  $ACB = 30^\circ$  and  $AC = 6$  cm.

The length of  $AB$ , in cm, is

(A)  $6\sin 30^\circ$

(B)  $\frac{6}{\cos 30^\circ}$

(C)  $\frac{6}{\tan 30^\circ}$

(D)  $\frac{6}{\tan 30^\circ}$

[Total: 10]

## SECTION II

**All working MUST be clearly shown for Questions 11 – 22 in the space provided after each Question**

11) \$ 8 000 in savings bonds are invested for 3 years at the rate of 2 % per annum compounded interest. Calculate

(i) the value of the investment after one year. [2]

(ii) the amount of interest received at the end of the investment period. [3]

12) Simplify fully  $\left(k^{\frac{2}{3}}\right)^3 \times k^2$ . [3]

13)  $\beta$  is directly proportional to the cube root of  $\alpha$ , and  $\beta = 5$  when  $\alpha = \frac{1}{8}$ . Using

this information

(i) Write an equation involving  $\beta$  and  $\alpha$ . [1]

(ii) Calculate the value of  $\beta$  when  $\alpha = 27$ . [3]

14) (i)  $r$  taken from  $y$  is at least 8. Write an inequality to represent this information. [3]

(ii) Given that  $y$  is an integer, determine the least value of  $y$  when  $r = \frac{4}{3}$ . [3]

**15)** Solve for  $x$  and  $y$ , the simultaneous equations:  $7x - 4y = 37$  [5]  
 $6x + 3y = 51$

- 16) (i)** Find the equation of the straight line passing through the points  $(2, -3)$  and  $(0, -2)$ . [2]  
**(ii)** Determine the equation of the line passing through  $(4, 1)$  which is perpendicular to the line at (i) above. [3]

17) Jeff is married with three children in school. In the year 2018, he earned a gross income of \$ 50 000.

<b>Tax-Free Allowances per year</b>
Personal Allowance: \$ 20 000
Each school-age child: \$ 1500. Maximum claim is 2 children.
<b>Tax Rates</b>
First \$ 10 000 of taxable income: 3 %
Remainder: 5.5 %

Using the information in the table above, calculate

- (i) his total tax-free allowances [3]
- (ii) his taxable income [1]
- (iii) the amount of income tax paid [5]
- (iv) his net income. [2]

18) An entrepreneur makes three sizes of bouquets; small, medium and large. Each bouquet contains roses, lilies and tulips. The table below shows some information about the number of bouquets made in one week.

(a) Complete the table below.

	Small	Medium	Large	TOTAL
Roses	7			23
Lilies		16		34
Tulips	3	8	2	
TOTAL	20		14	

[7]

Write your responses to part (b) in the space provided at the top of the next page.

- (b) One of the bouquets is selected at random. Determine the probability that the bouquet
  - (i) is medium
  - (ii) is made from tulips
  - (iii) is large and made from lilies
  - (iv) is small given that it is made from roses
  - (v) is made from roses given that it is medium [5]

- 19) A group of students each recorded the distance they travelled daily to reach school. The distance, to the nearest kilometre, is recorded below:

<b>Distance in kilometres</b>	<b>Frequency</b>
1 - 5	5
6 - 10	2
11 - 15	4
16 - 20	8
21 - 25	3
26 - 30	3

(i) State the modal class.

[1]

(ii) Calculate the mean distance travelled.

[8]



- 20) The figure below, not drawn to scale, represents a bird cage in the form of a cylinder surmounted by a cone. The diameter of the cylinder is 35 cm and its height is 25 cm. The total volume of the cage is  $31\,178\text{ cm}^3$ .

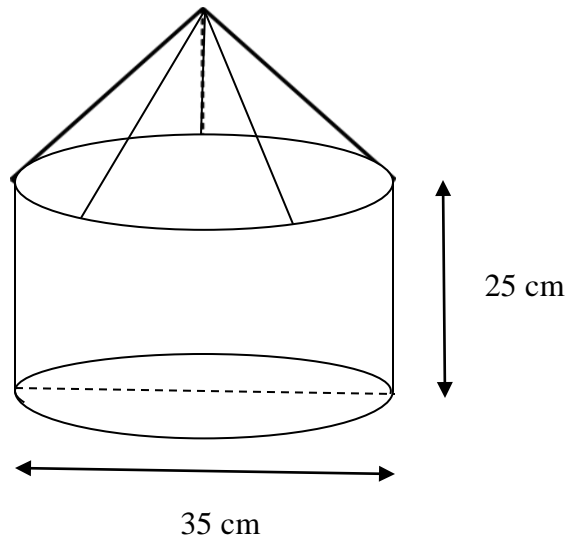

Using  $\pi = \frac{22}{7}$ , calculate the total height of the cage

[5]

21) The diagram below, not drawn to scale, shows the sector of a circle  $OABC$ .

$OA = 7$  cm,  $AC = 8.03$  cm and angle  $AOC = 70^\circ$ .

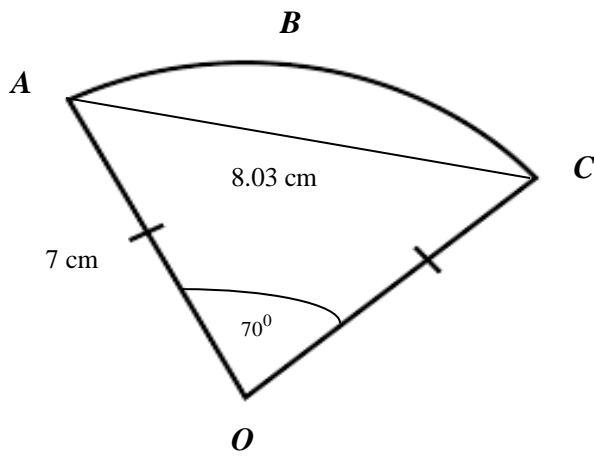

Taking  $\pi = 3.142$ , calculate correct to two decimal places

(i) the area of triangle  $OAC$

[3]

(ii) the area of the segment  $ACB$ .

[3]

**22)** A man 1.5 metres tall is standing at a point  $A$  on the horizontal ground. His feet are 10 metres away from the base,  $B$ , of a cell phone tower,  $BT$ , which is 18 metres high.

(i) Sketch a fully labelled diagram to show ALL of the above information. [6]

(ii) Calculate an estimate of the angle of elevation of the top,  $T$ , of the tower from his eyes. [3]

**End of Examination**